

# Product Datasheet

## Swing PZA Q517

Aluminum square  
profile  
90 x 90



[m]

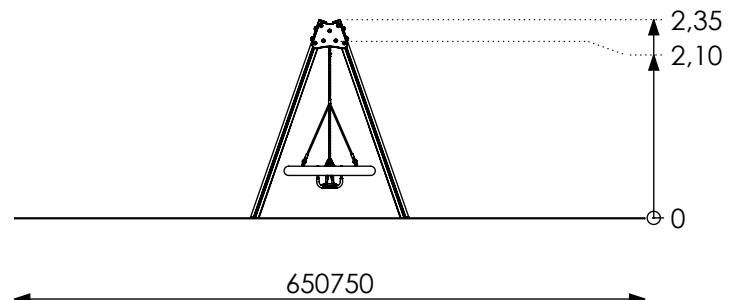
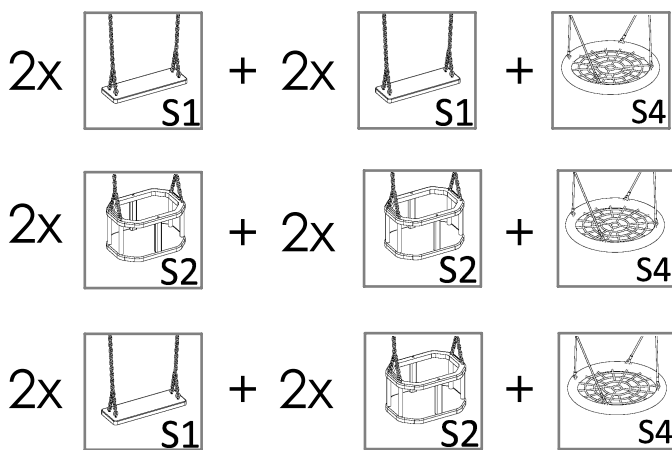

[cm]

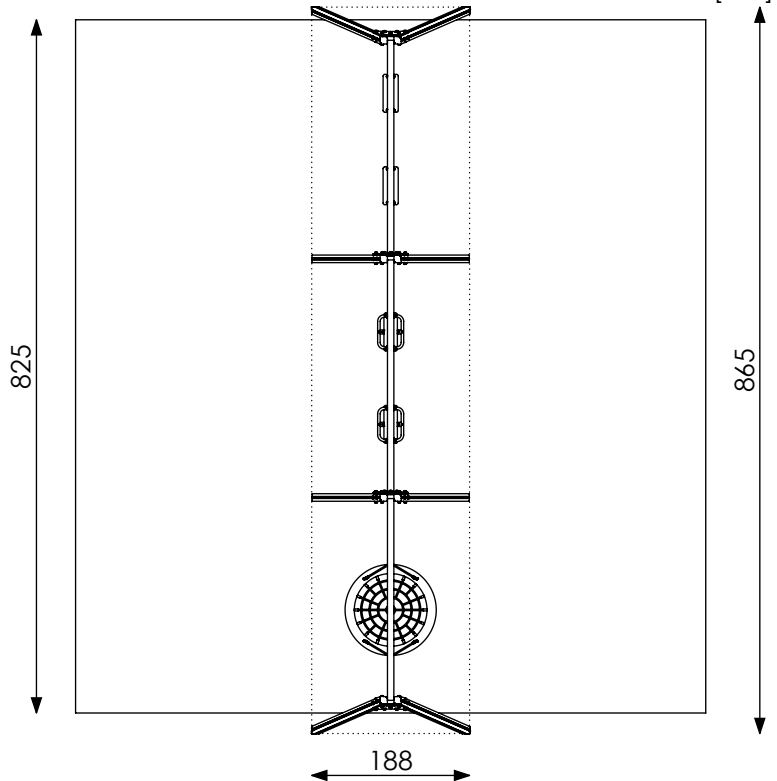

Age:  
- 3+  
- 0-3 years (baby box seat)

Amount of users: 10

Safety zone:  
- for loose surface: 825 x 750 cm (61,9 m<sup>2</sup>)  
- for rubber safety flooring: 825 x 650 cm (53,6 m<sup>2</sup>)

Free fall height: 125 cm

Weight of the playset: 225 kg  
Dimension of the biggest part: 320x9x9 cm

Product compliant with PN-EN 1176-1,  
PN-EN 1176-2+AC: YES  
Spare parts availability: YES

## Mounting:

The set is mounted in the ground.  
Foundations made of C20/25 concrete.

## Material specification:

- Construction poles made from aluminum square profiles 90x90 mm with reinforcements with anodized finish.
- Steel pipe beam  $\varnothing 76,1 \times 3,2$  mm, hot dip galvanized.
- Slings with bearings, maintenance-free, hot dip galvanized or stainless steel with swivels.
- Top of the poles secured by cap made from HDPE.
- Screws, bolts etc. covered by colorful plugs from plastic.
- Stainless steel chains.
- Rubber seats with aluminum insert.
- "Birdnest" seat with reinforced ropes in a polypropylene braid  $\varnothing 16$  mm.

Renders are for reference only, actual appearance may differ from the one shown on the render.

### Acceptable shock absorbing surfaces and their minimum thickness

Material <sup>a</sup>	Description [mm]	Minimum depth <sup>b</sup> [cm]	Maximum free heights of fall [cm]
Turf/topsoil		-	$\leq 100$ <sup>d</sup>
Bark	20 to 80 particle size	20	$\leq 200$
		30	$\leq 300$
Woodchip	5 to 30 particle size	20	$\leq 200$
		30	$\leq 300$
Sand or gravel <sup>c</sup>	0,25 to 8 grain size	20	$\leq 200$
		30	$\leq 300$
Other materials	As tested according to EN 1177		Critical fall height as tested

<sup>a</sup> For further information on specific material properly prepared for use in children's playgrounds

<sup>b</sup> For loose particulate material, add 100 mm to the minimum depth to compensate for displacement (see 4.2.8.5.1).

<sup>c</sup> Sand and gravel shall be well rounded and washed to eliminate most of the silt or clay particles. Washed sand and gravel is considered to be from alluvial (natural eroded) deposits and free from most silt or clay particles. For gravel this may commonly be described as 'pea shingle'. Uniformity coefficient  $D_{60}/D_{10} < 3,0$ . Grain size can be identified by use of a sieve test, as in EN 933-1 (see Annex G)

<sup>d</sup> See NOTE 2 in 4.2.8.5.2